

NOX-FILT Inline Carbon Filter

Installation Instructions

1.0 Introduction

The NOX-FILT has been created by Domus Ventilation to work in conjunction with a mechanical ventilation system to reduce harmful airborne contaminants entering the home, with a leading focus on NO₂ filtration. It benefits from a shallow design allowing flexible, discreet install in modern buildings with space restrictions and requires no mechanical maintenance, simply the replacement of filters. The unit incorporates a carbon filter as standard, and is available with PM2.5 pre-filter. These units should be fitted on the supply leg of ducting and therefore do not require insulation (Figure 2).

| Unit Code | Height (mm) | Width (mm) | Length (mm) | Max. Weight (kg) |
|-------------|-------------|------------|-------------|------------------|
| NOX-FILT | 170 | 346 | 858 | 15.1 |
| NOX-FILT2.5 | 170 | 346 | 858 | 15.5 |

CODE DESCRIPTION:

NOX-FILT2.5

1 2

1. Inline Carbon Filter

2. Optional Particulate Pre-Filter:
2.5 = PM2.5 (2.5 microns +)

1.1 Particulate Filter (Optional)

High urban PM (Particulate Matter) emissions may require an additional filter to meet air quality standards.

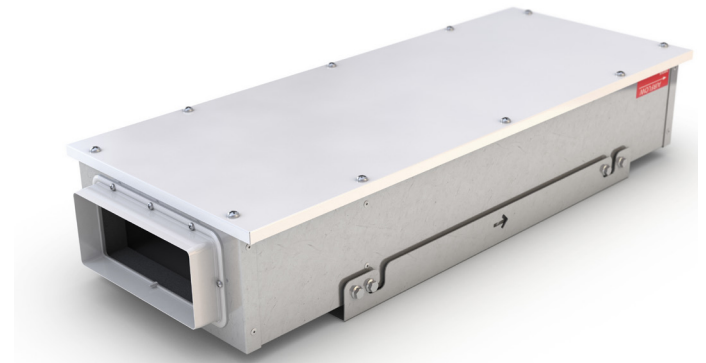

1.2 Performance Data

These carbon filters have been independently tested and offer up to 99.5% reduction in NO₂. The unit meets planning obligations and world health organisation's recommendations.

1.3 Resistance Data

When selecting the MVHR unit please ensure that the resistance through the carbon filter has been allowed for.

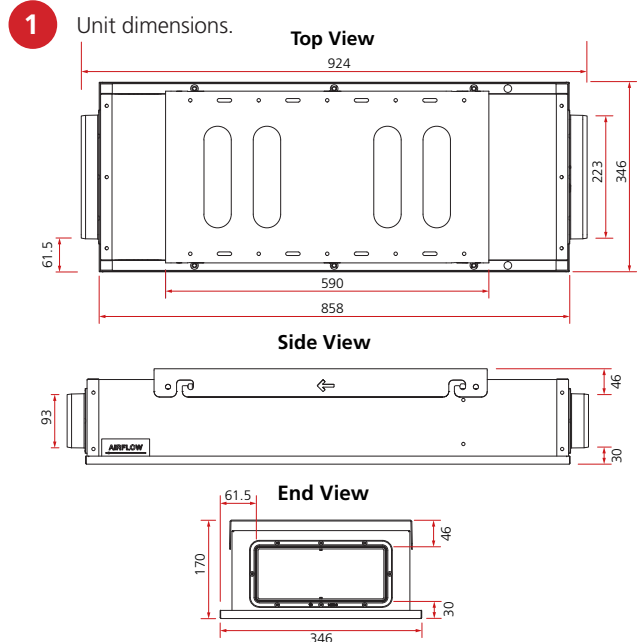

2 Typical example of a HRXE unit with NOX-FILT installed in the supply ducting.

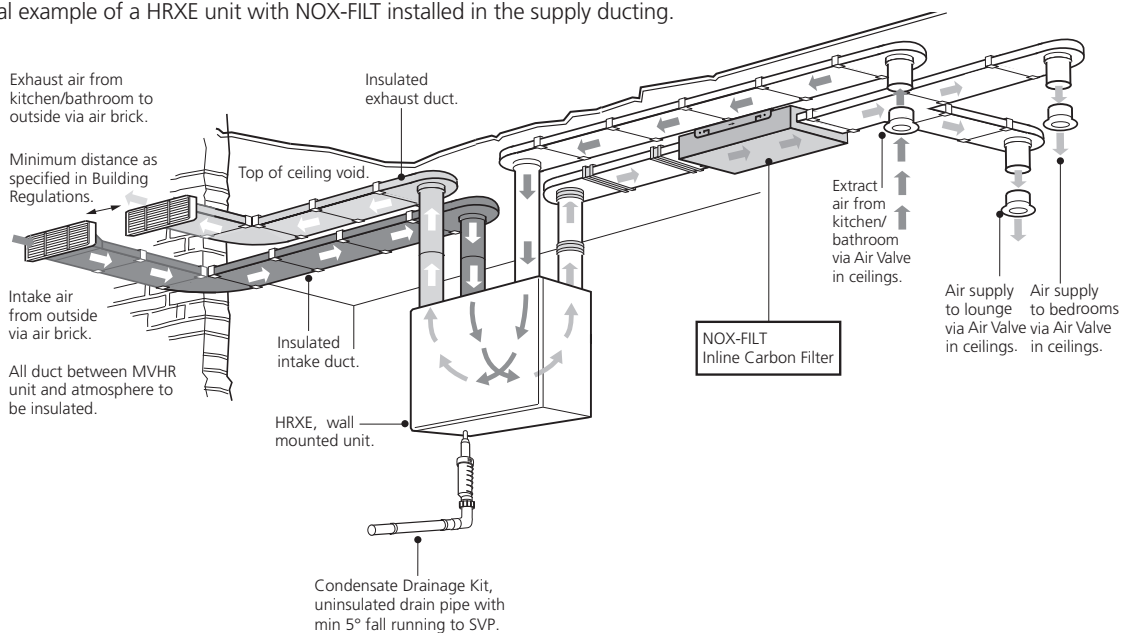

2.0 Installation

Installation must be carried out by competent personnel, in accordance with good industry practice, the appropriate authority and in conformance with all statutory and governing regulations.

The mounting surface must be of a solid construction and capable of supporting the full weight of the unit.

Units are supplied complete with a mounting bracket for quick and easy surface mounted installation.

Access to the unit for maintenance is granted via the bottom panel. Ensure that an access panel has been allowed for maintenance to the unit, the space required is shown below.

2.1 Ceiling Mounting

- ▶ Remove unit from packaging and unscrew the outer locking bolts (two bolts on the left and right side of the unit) from the mounting bracket, storing them for later use (Figure 3).
- ▶ Loosen the inner mounting bolts and slide/lift the mounting bracket off the unit (Figure 4).
- ▶ Locate the mounting bracket into the desired position, with the arrows pointing in the direction of airflow. Use the bracket to mark the required drill holes.
- ▶ Using the appropriate fixings, secure the bracket to the ceiling.
- ▶ Check the orientation of the unit matches that of the mounting bracket by aligning the direction of the arrow on the bracket with the direction of the arrow on the units' airflow label.
- ▶ With the inner mounting bolts still protruding from the unit (5mm), offer the unit up to the mounting bracket, sliding up and across so that all four bolts rest in the bracket slots. Tighten all bolts.
- ▶ Lock the unit in position by refitting the outer locking bolts that were removed earlier.

3 Outer locking bolts.

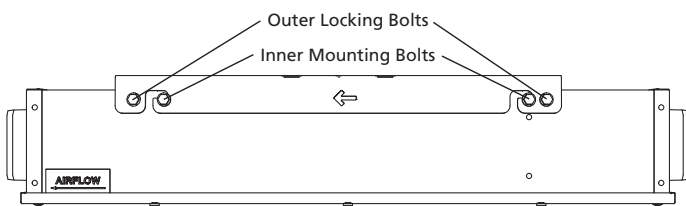

4 Removing mounting bracket.

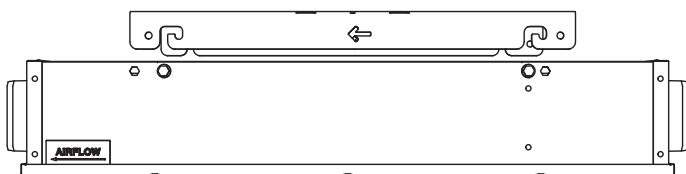

2.2 Limited Access

It is possible to fit this unit close to a wall/obstacle which prevents the locking bolts from being installed along one side. The two unused locking bolt holes should be plugged by screwing in the rubber plugs provided before installing. All four mounting bolts **MUST** be tightened and the remaining two locking bolts **MUST** be used.

3.0 Maintenance

Appropriate PPE (Personal Protective Equipment) should be worn during maintenance. Precautions may also be needed to protect the surrounding area from excess carbon residue.

To ensure the carbon filter maintains its high reduction of NO₂ the filter must be replaced once the end of its lifespan has been reached. The lifespan of the carbon filter in normal circumstances is shown in the table below.

| Unit Code | Carbon Filter | |
|-------------|---------------|-------------|
| | Lifespan | Weight (kg) |
| NOX-FILT | 2 Years | 6 |
| NOX-FILT2.5 | 2 Years | 6 |

IMPORTANT INFORMATION:

The carbon filter block is supported by a retaining clamp, loosening the clamp will result in the filter being freed. Be prepared to support the whole weight of the carbon filter block.

3.1 Replacing Single Carbon Filter - NOX-FILT/NOX-FILT2.5

- ▶ Unscrew the fixings securing the lid in place and remove lid from unit (Figure 5).
- ▶ Whilst supporting the back of the carbon filter block, loosen the retaining clamp bolt and rotate the clamp in order to release the block (Figure 6).
- ▶ Pulling firmly on the rear edge of the carbon filter block will lever the filter to approximately a 45° angle (A). At this position it can be removed from the unit (B) (Figure 7).
- ▶ Replace the carbon filter in the reverse operation to the above process. Ensure the filter is worked into position, the clamp rotated back and clamp bolt tightened prior to removing support from the replacement carbon filter block.
- ▶ Refit the unit lid.
- ▶ Wash hands thoroughly after handling.

5 Unit access.

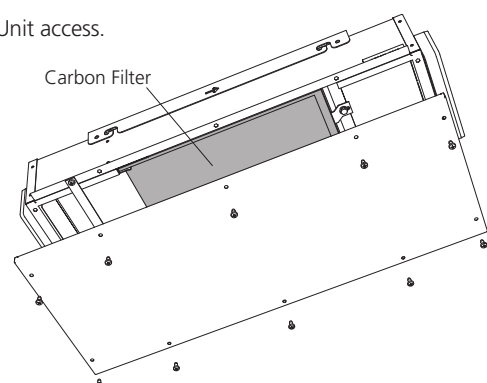

6 Carbon filter block retaining clip.

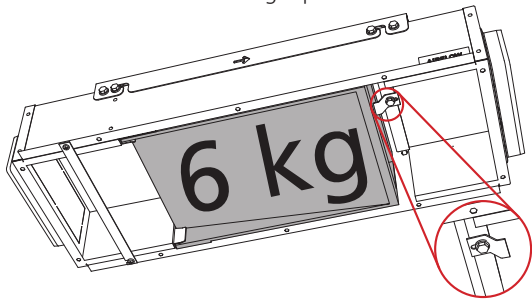

7 Carbon filter block removal.

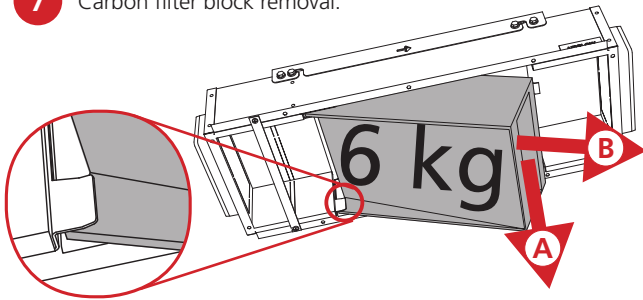

IMPORTANT INFORMATION:
Carbon filters / pellets are not to be ingested.

3.2 Replacing Particulate Filter (If Applicable)

To ensure effective particulate matter filtration and low system resistance, the optional PM2.5 air filters must be replaced every 12 months. Replacement filters are available for purchase direct from Domus Ventilation, with the relevant part codes shown in section 3.3 of this document.

- ▶ Unscrew the fixings securing the lid in place and remove lid from unit (Figure 5).
- ▶ Rotate the strap through 90° to allow removal of the filter, the fixing screw may need to be loosened to allow strap to rotate (Figure 8).
- ▶ Fit the replacement filter ensuring the airflow direction matches the air flow of the unit (if applicable).
- ▶ Rotate strap back into position and refit unit lid.

8 Particulate filter removal (if applicable).

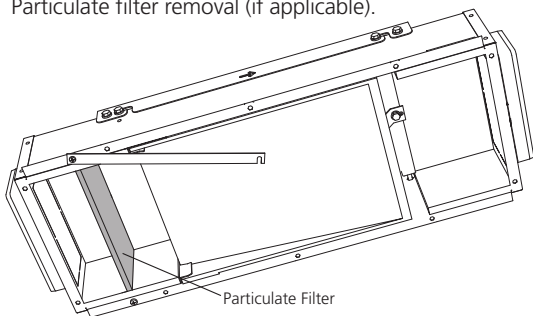

Technical or commercial considerations may, from time to time, make it necessary to alter the design, performance and dimensions of equipment and the right is reserved to make such changes without prior notice.

Domus Ventilation

Block C, Van Court, Caerphilly CF83 3ED, United Kingdom
Email: vent.info@domusventilation.co.uk
Tel: 03443 715 523

www.domusventilation.co.uk

3.3 Replacement Filters

Replacement filters can be purchased direct from Domus using codes provided in the table below.

| Unit Code | Carbon Filter | Particulate Filter |
|-------------|---------------|--------------------|
| NOX-FILT | NOX-CF | N/A |
| NOX-FILT2.5 | NOX-CF | NOX-PM2.5 |

Please visit our spares website to purchase replacement filters
<http://vent-spares.domusventilation.com/>

4.0 Warranty

The 5 year warranty starts from the day of delivery and includes first year parts and labour, remaining years parts only. This warranty is void if the equipment is modified without authorisation, is incorrectly applied, misused, disassembled, or not installed, commissioned and maintained in accordance with the details contained in this manual and general good practice.

The product warranty applies to the UK mainland and in accordance with Clause 14 of our Conditions of Sale. Customers purchasing from outside of the UK should contact Domus Ventilation Sales office for further details.

5.0 After Sales

For technical assistance or further product information, including spare parts and replacement components, please contact the After Sales Department.

Telephone 03443 715 523
vent.technical@domusventilation.co.uk