

DBF100

100mm (4") Intermittent axial range

Provides effective ventilation to comply with current building regulation standards.



Dimensions (mm)

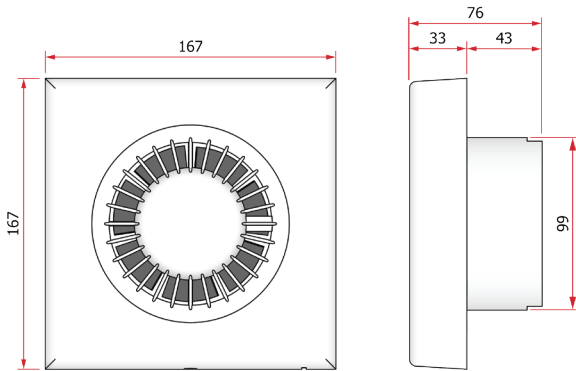

Code	Description
DBF100B	Basic Fan
DBF100-PC	Pull Cord Control
DBF100-T	Timer Control
DBF100-HT	Humidistat and Timer Control

SOUND PERFORMANCE

Unit	Duty (l/s)	Sound Power Levels dB re 1pW (Frequency Hz)									dBA @3m
		63	125	250	500	1k	2k	4k	8k	LwA	
DBF100	18.6	39	41	53	49	52	45	41	33	55	34

Performance

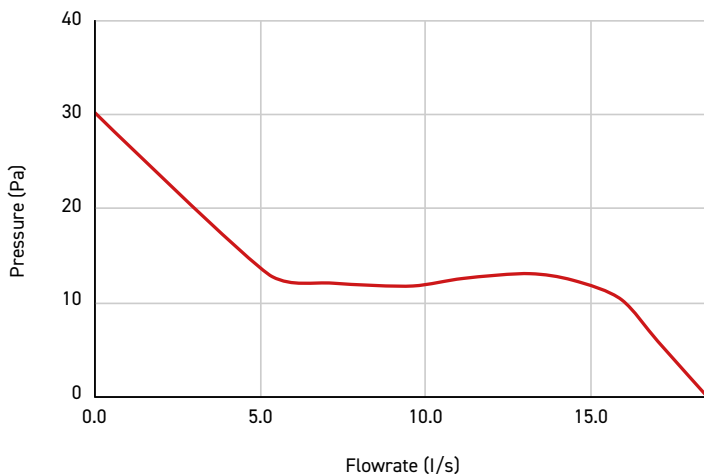

TECHNICAL DATA

Description	Value	Units
Max Extract Volume	18.6	(l/s)
Max Extract Volume	66.96	(m ³ /H)
Max Pressure	30.2	(Pa)
Supply Frequency	50	(Hz)
Specific Fan Power	0.49	(W/l/s)
Max Power	8	(W)
Max Sound Level	34	dB(A) @3m
Weight	0.6	(kg)
IP Rating	X4	N/A
Max Operating Temperature	40	(°C)
Wall-Fit Hole Diameter	110	(mm)
Warranty	2	Years

YOUR VENTILATION SPECIALIST

03443 715 523

www.domusventilation.co.uk



For compatible ducting kits please refer to the "Kits" section in the Domus Specification Guide.

©Domus Ventilation 2024. Issue date 2024-08.

The information contained in this publication is correct at the time of print and is subject to change. Please visit our website for the latest information: www.domusventilation.co.uk.

Domus Ventilation | Western Industrial Estate, Caerphilly, CF83 1NA, UK.